

BTnodes



Robust Topology Discovery and Positioning Services

Jan Beutel

TIK
Computer Engineering
and Networks Laboratory

Outline

Highlight the idiosyncrasies of multihop ad hoc networking services on real devices

Network based positioning and topology discovery

BTnode - Ad hoc networking prototyping platform

Constructing network topologies using Bluetooth

Implementation of a robust, self-healing tree topology

Topology discovery and positioning

Finding the position of networking nodes

- by using the network properties and it's services

Optimizing for

- topology, bandwidth, power, interference...

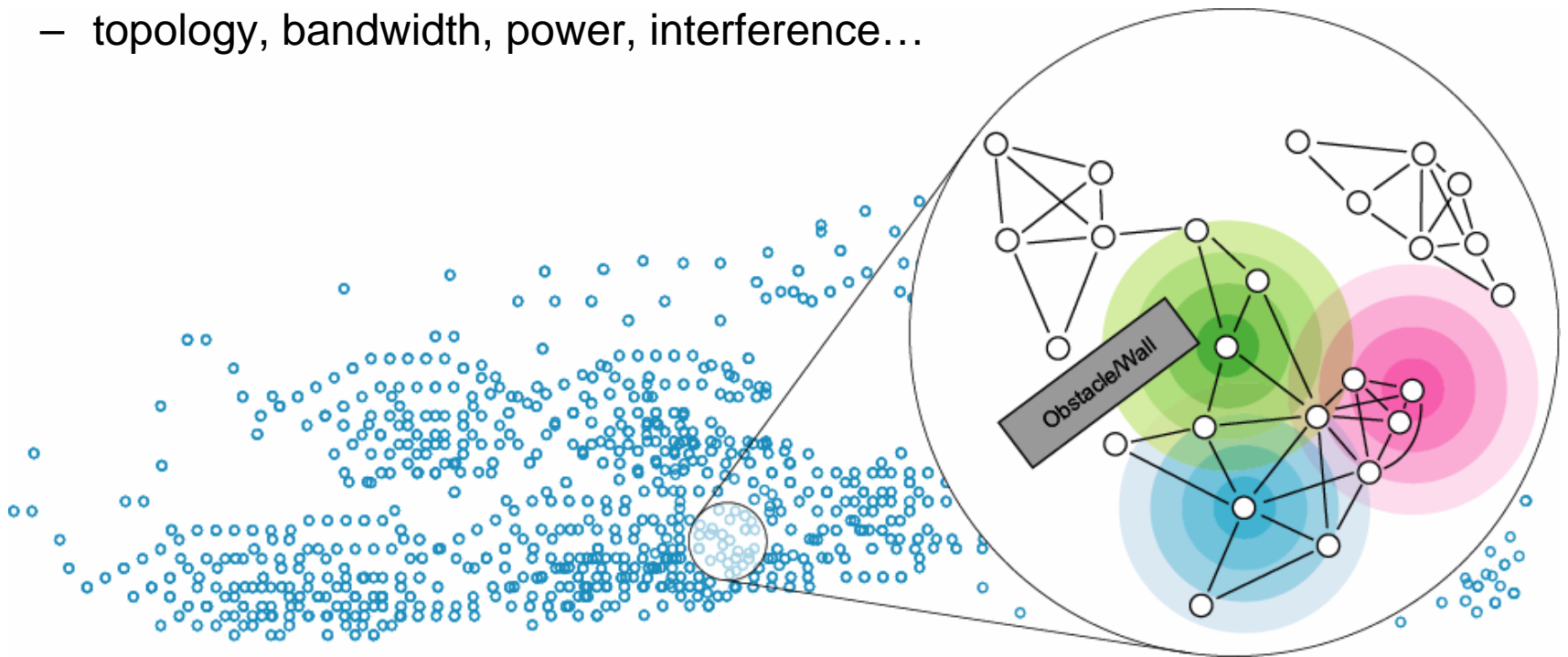

Positioning modes

Relative Positioning

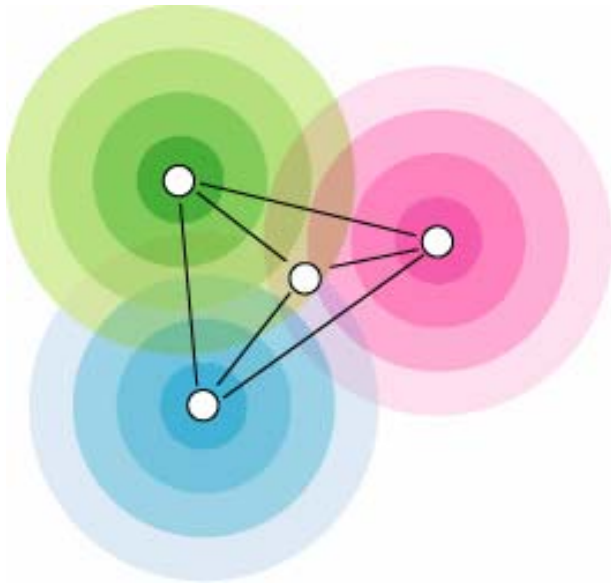

connectivity and distances,
topology between nodes

Absolute Positioning

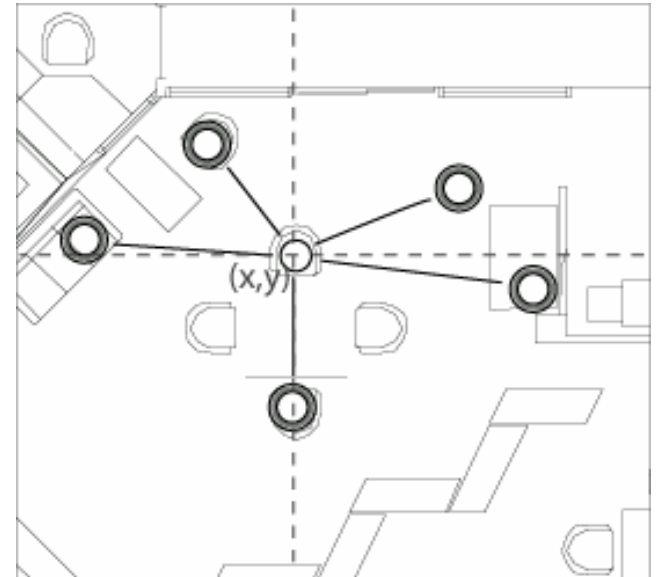

reference positions,
orientation, maps, context

Problem range estimation

Range estimation of radio signals is a problem

- signal propagation
- system dynamics
- limited resources
- lack of specialized transceivers

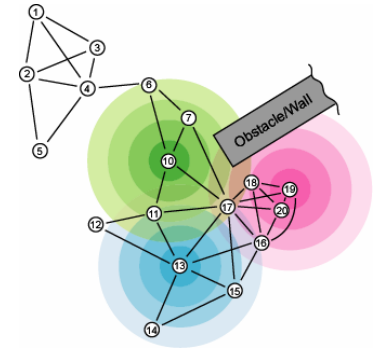

Solution: Redundant trilateration

- similar to GPS or cell-based positioning

Strongly over determined topologies

- leveraging costly hardware
- operating with large range errors
- adapting to the environment

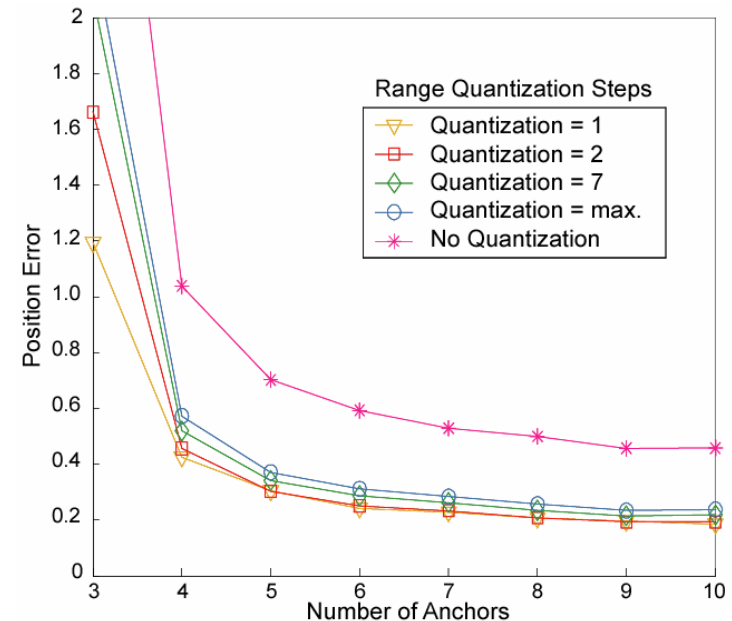

Distributed algorithm solutions

Network based positioning through distributed trilateration

- redundant, overlapping cell based positioning
- adapted to multihop

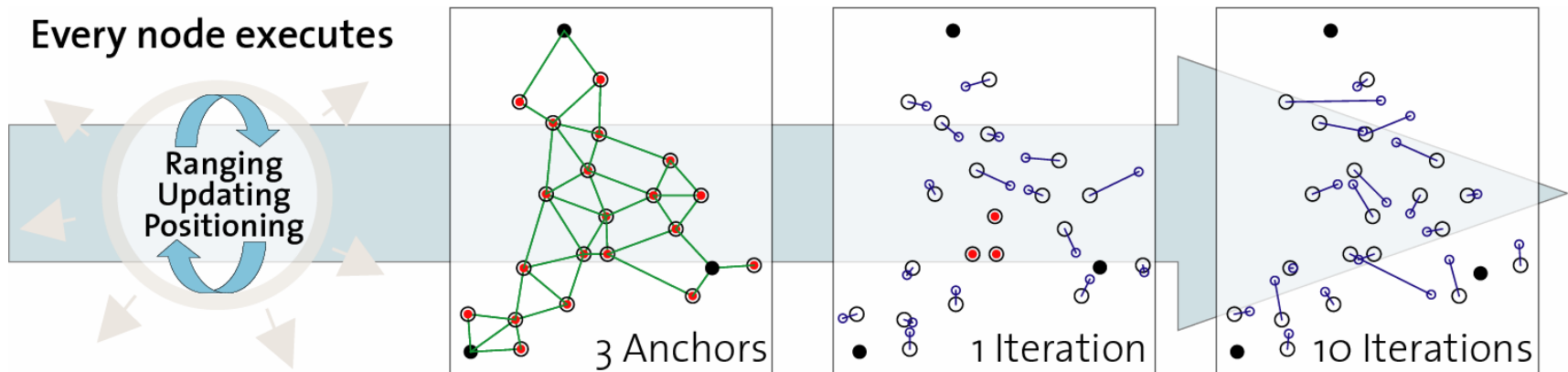

Different algorithms proposed

- [Savarese2001, He2003, Capkun2002, Savvides2001, Doherty2001, Bahl2000, ...]

Positioning and network topologies

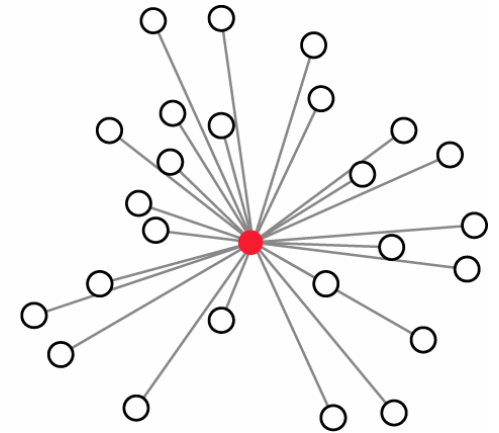
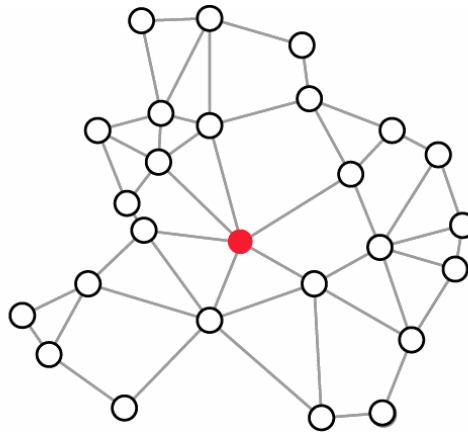
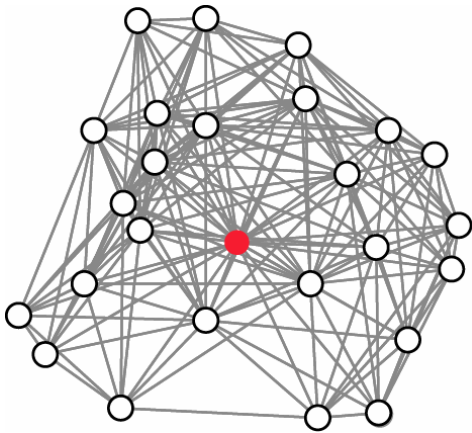

Performance in network based positioning depends on the available topology for data gathering and dissemination.

Routing algorithms often have different requirements.

Robust topology discovery

Integration of efficient routing and positioning services

Common operations in routing and positioning

- node identification, connection management, data exchange and handling

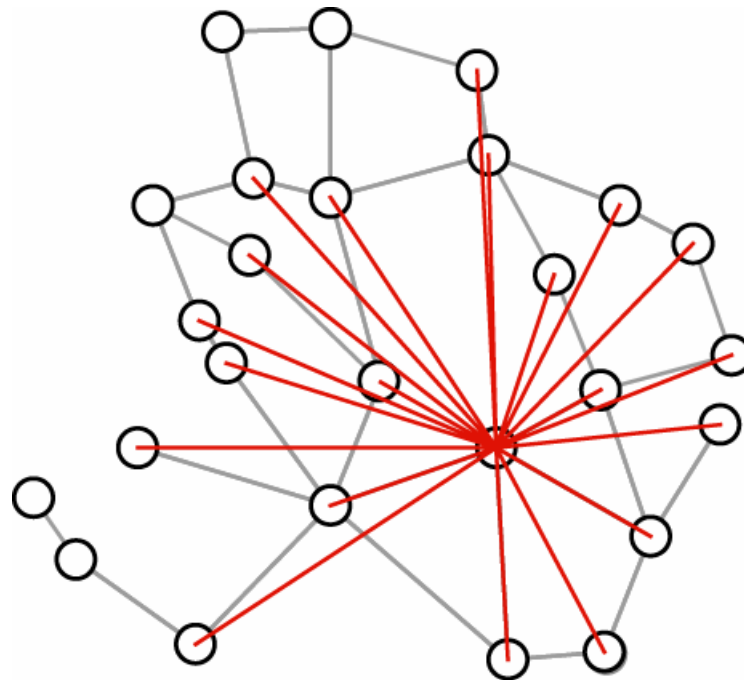

Constructing large network topologies

How to construct an ad hoc network topology with Bluetooth

- large network, many devices
- all devices connected, supporting transparent multihop transport

Understanding the limits and benefits of Bluetooth

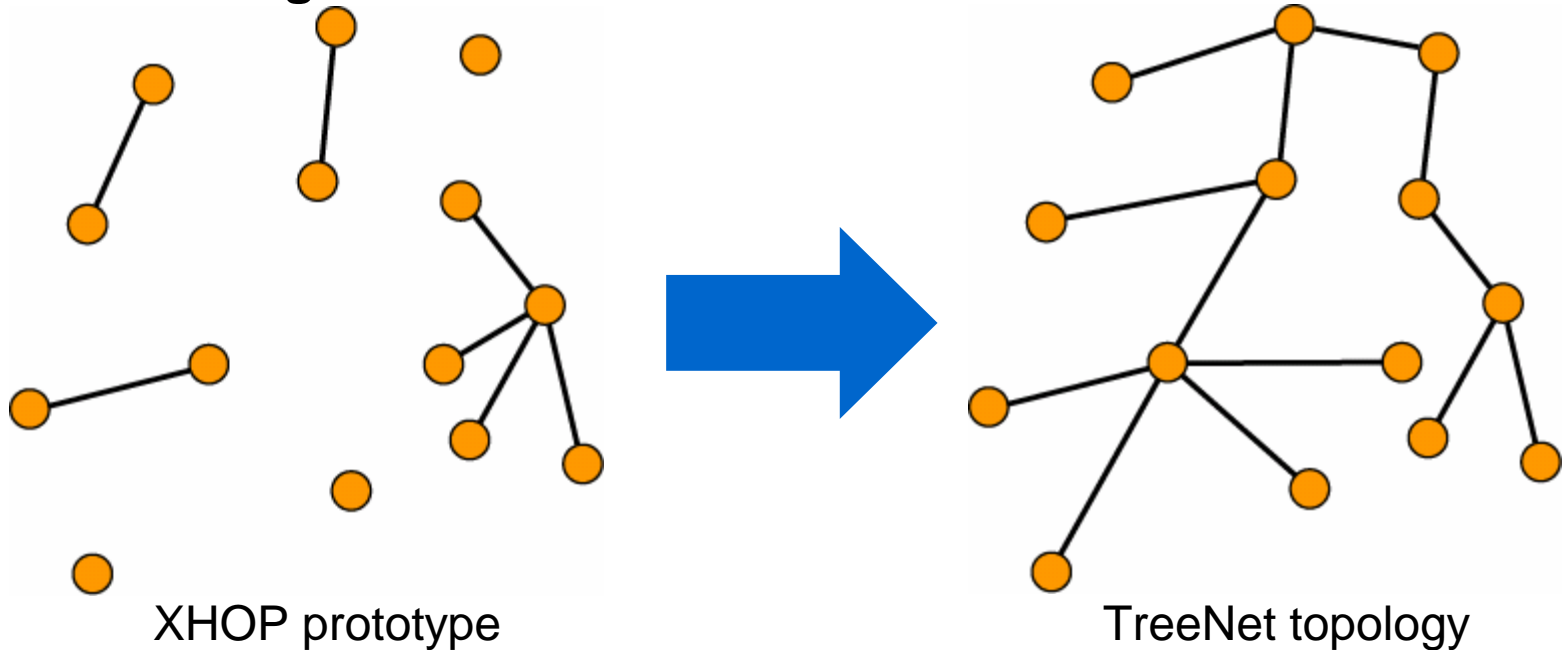

BTnode architecture

Lightweight wireless communication and computing platform based on a Bluetooth radio module and a microcontroller.

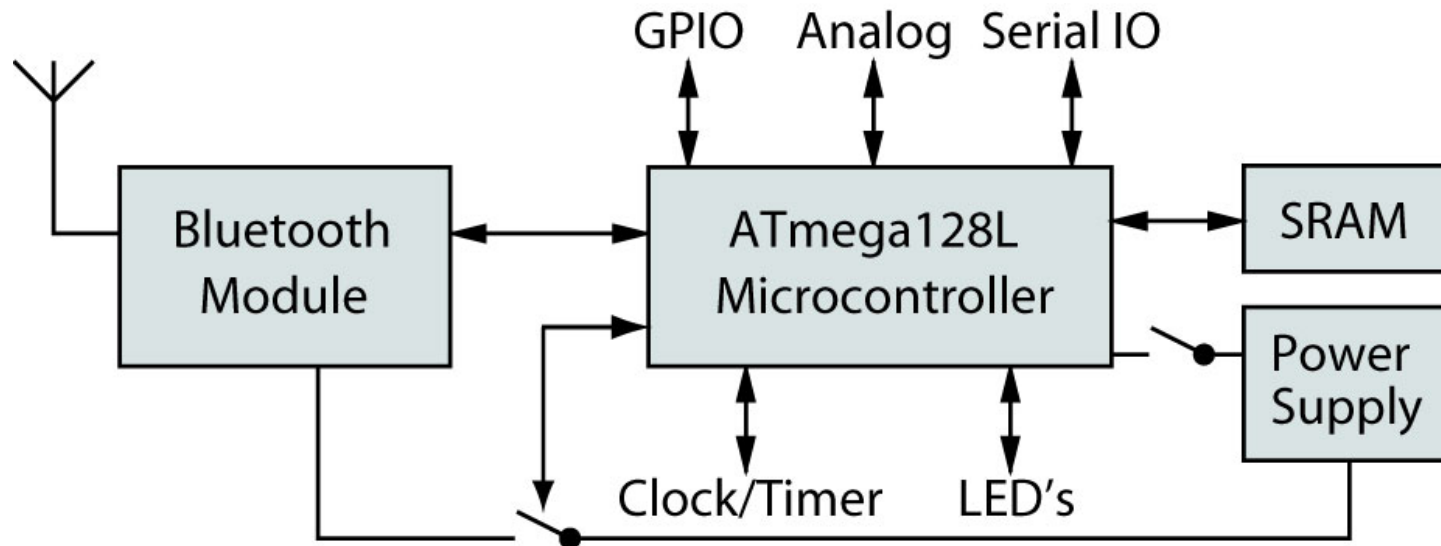

Bluetooth has the advantage of

- availability today for experimentation
- compatibility to interface to consumer appliances
- an abstract, standardized high level digital interface

Bluetooth prototyping platform

Integrated hardware features

- 8-Bit RISC, max. 8 MIPS, 128 kB Flash, 64 kB SRAM, 180 kB data cache
- operating from 3 cell batteries
- generic sensor interfaces

Event-driven lightweight OS

- standard C language
- system software available as library

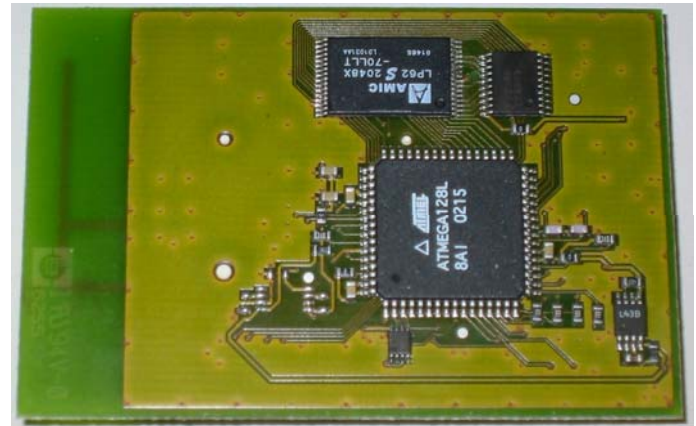
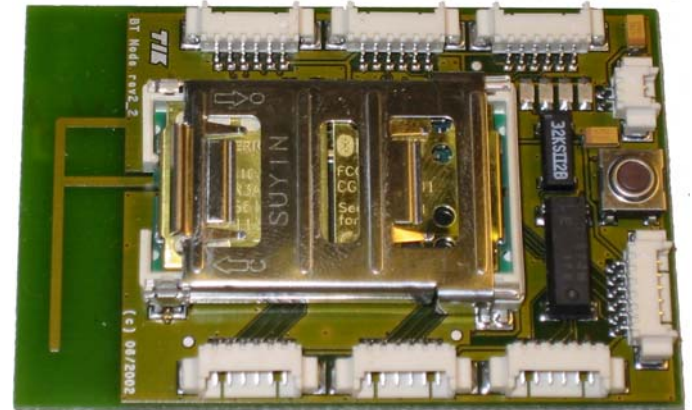

Current bill of material	50 parts
Parts	60 USD
Assembly	5 USD
Bluetooth	45 USD
<hr/>	
Unit cost @ 200 units	110 USD

Other BTnode applications

Many successful BTnode applications

- The Lighthouse location system [Roemer2003]
- Smart product monitoring [Siegemund2002]
- Bluetooth enabled appliances [Siegemund2003]
- Smart It's friends [Siegemund2003]
- XHOP/R-DSR multihop prototype [Beutel2002]
- Distributed positioning – TERRAIN implementation [Frey2003]
- Physical activity detection network [Junker2003]
- Better avalanche rescue through sensors [Michahelles2002]
- Wearable unit with reconfigurable modules [Plessl2003]
- Undergrad projects with Lego Mindstorms [Blum2003]
- ...

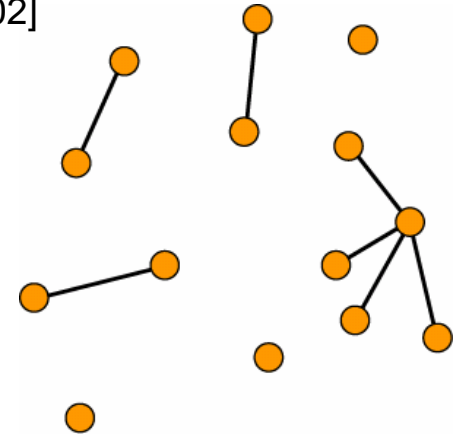
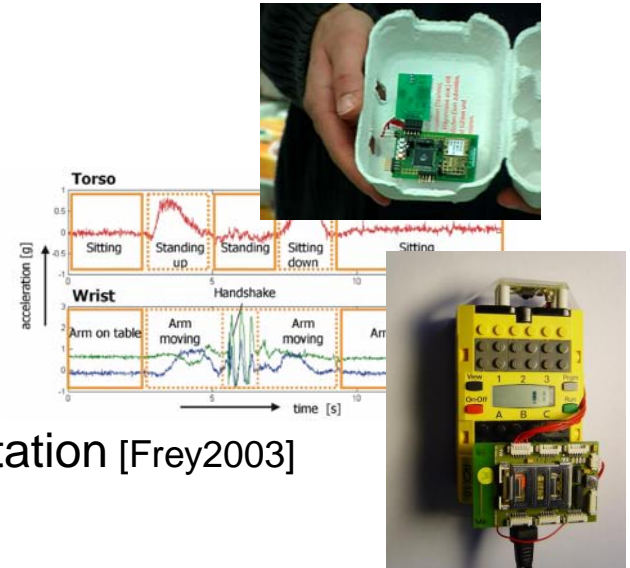

Mostly relying on simple point to point data links

Constructing network topologies

Scatternet formation algorithms

- many theoretical studies and simulations often far away from reality
- improvements in the current Bluetooth voting draft specification v1.2

BlueStars [Basagni2002/3], BlueRing [Lin2003] ...

- make assumptions on physical prerequisites not available today
- assume “perfect” connection performance
- assume symmetric data availability on nodes



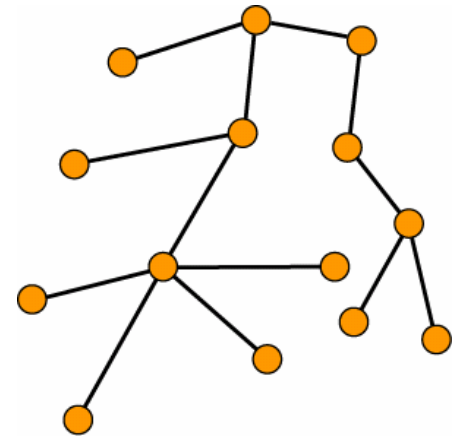

Ad hoc network topologies only in simulations

- usually all using the same underlying physical models
- often lacking realistic distributed system models for large networks
- limited access to appropriate hardware devices



BTnode networking – definitions

Four states

- IDLE 
- MASTER 
- SLAVE 
- MASTERSLAVE 

Useful operations

- *inquiry()* – find other nodes
- *connect()* – open connection
- *roleSwitch()* – change MS relation
- *sendData()* – data transport

Hardware limitations on the BTnodes/Bluetooth

- max. 7 active slaves in one Piconet
- while in *inquiry()* and *connect()* a node is not visible
- while in SLAVE or MASTERSLAVE a node is not visible
- while in SLAVE or MS a node cannot do *inquiry()* or *connect()*
- *inquiry()* and *connect()* have long delays and no a priori guarantee

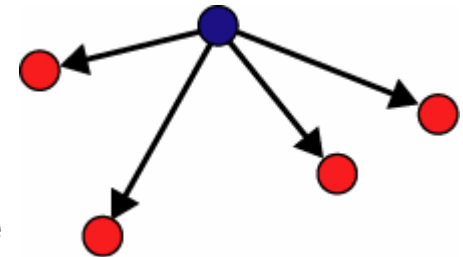

Bluetooth only defines single hop Master-Slave data transport

Distributed Bluetooth Piconets

Distributed *inquiry()* and *connect()* is a problem

- nodes are uncoordinated
- limited visibility
- asymmetry: inquired node doesn't notice

Inquiry() and *connect()* have long delays

- state change in remote node goes unnoticed
- average delay in seconds [Kasten2001]
- no a priori guarantee for success

Inquiry() and *connect()* are highly nondeterministic (both in timing and function)

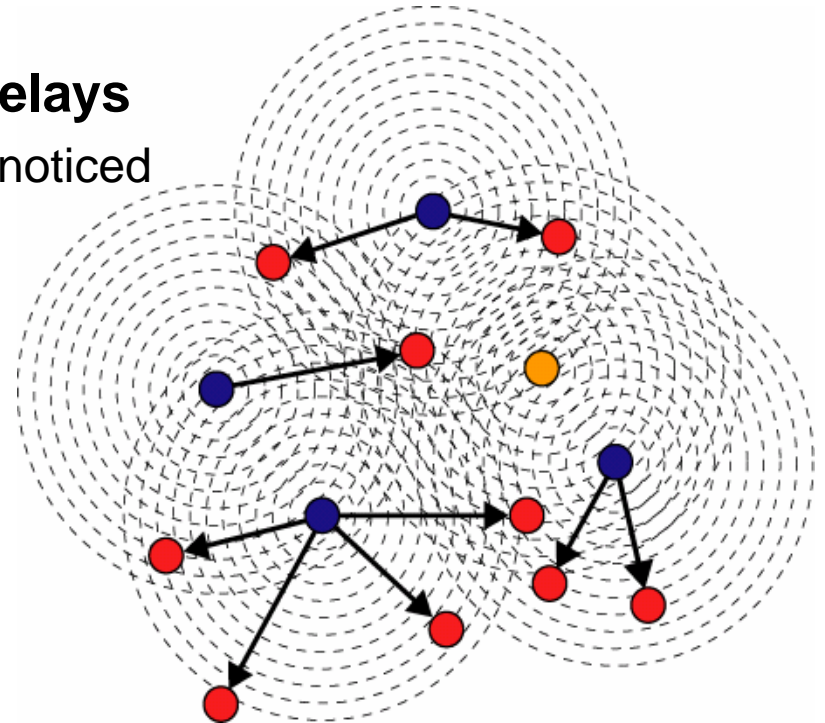

Bluetooth applied

Purpose of this study:

How can we construct 'arbitrarily' large trees in a robust and distributed way?

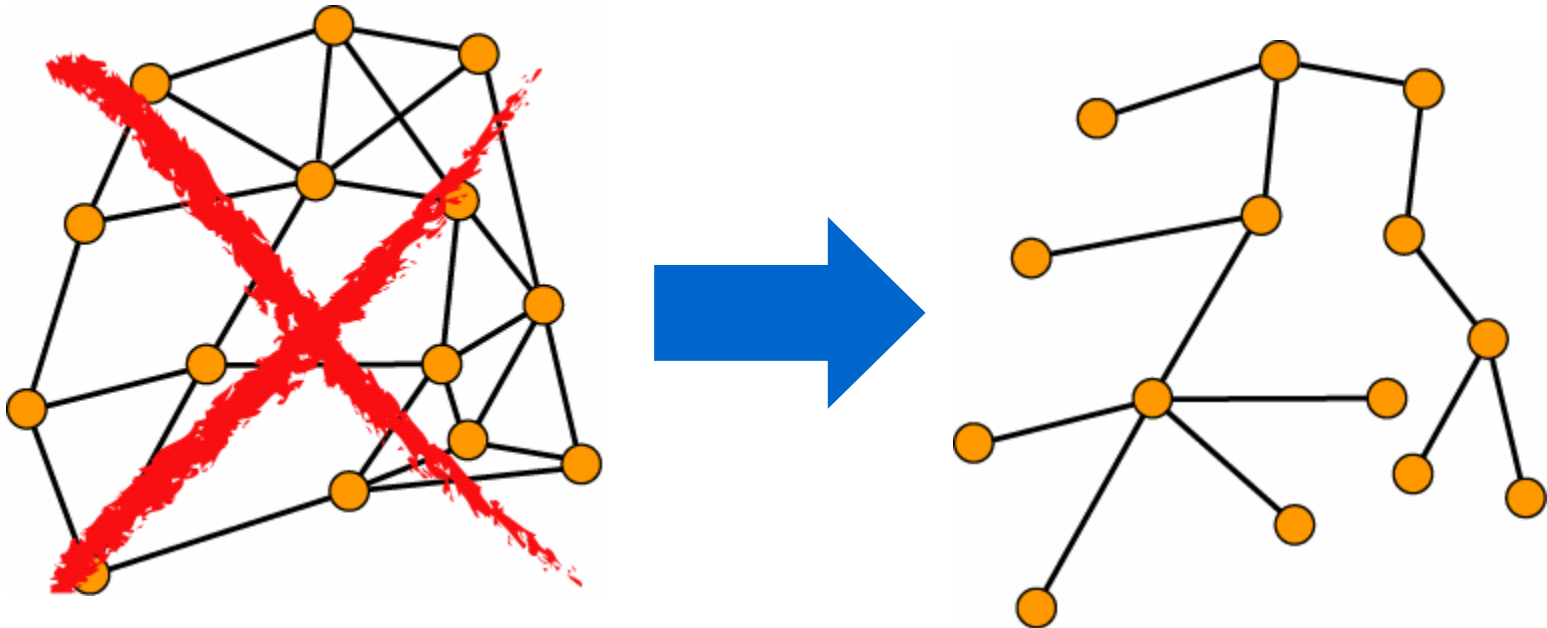

TreeNet simple tree construction

Every node executes algorithm

- until single tree is reached

Formation of large topologies

- robustness
- simplicity
- redundancy
- distribution
- self-healing

Services and applications can break up trees later

- forming other topologies
- optimizing topology

```
loop {  
  inquiry();  
  forall (nodes_found) do {  
    while (not_max_degree)  
      connect();  
  }  
}
```

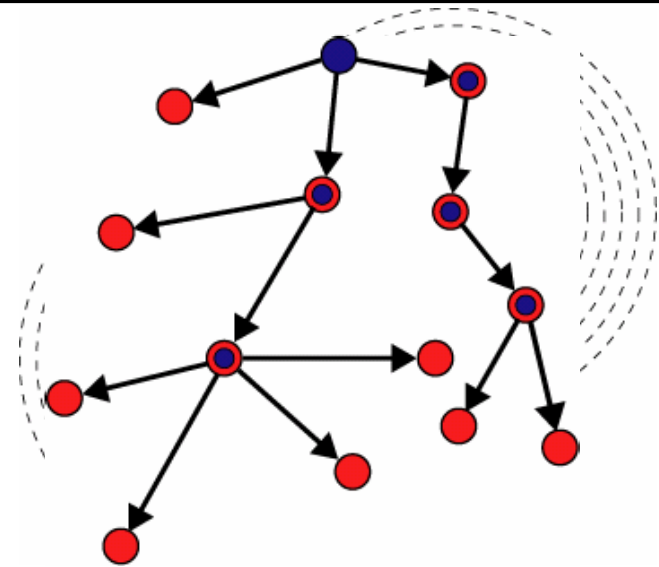

TreeNet Demo at Monte Verita

Shown at MICS Annual Review



NCCR_MICS_MOBILE_INFORMATION_AND_COMMUNICATION_SYSTEMS

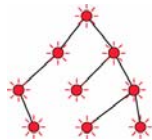
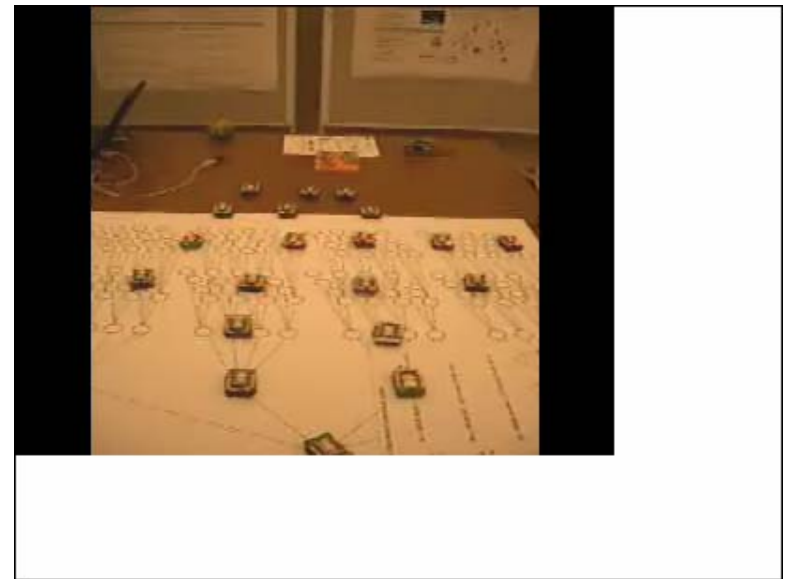
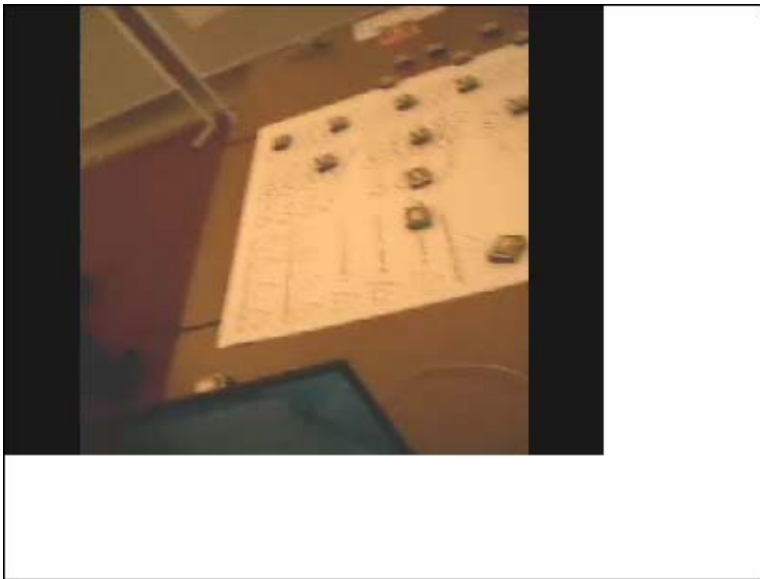

ba – Blink All – all nodes flash once



b – Blink Levels – starting from the root, all levels flash once

TreeNet discussion

Nodes must all be in visible range

Might not fully connect if multiple `max_degree` roots form

- rebuilding of partial trees necessary if nodes cannot connect at root

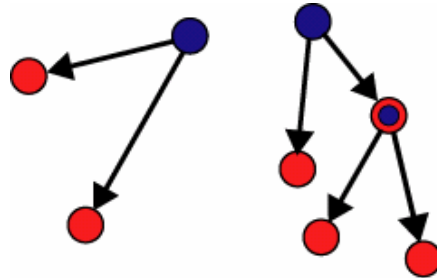

Simple greedy algorithm reduces `inquiry()` and `connect()`

- better performance by caching and time-stamping `inquiry()` and `connect()`
- try to `connect()` to node-last-seen first
- exchange of topology data and adaptive `connect()` retries

In reality a 5 line algorithm ends up to be ~2000 lines of code!

Large scale distributed deployment

So why do we actually need ~4000 lines of code?

- 5 lines -> 2000 lines + system software + debugging and monitoring
- result in an ~87 kB program (un-optimized)

Necessary node functions

- data exchange
- timing and time-stamps
- data storage and handling (persistent and volatile)
- stepwise testing and deployment
- distributed reprogramming
- distributed debugging and monitoring

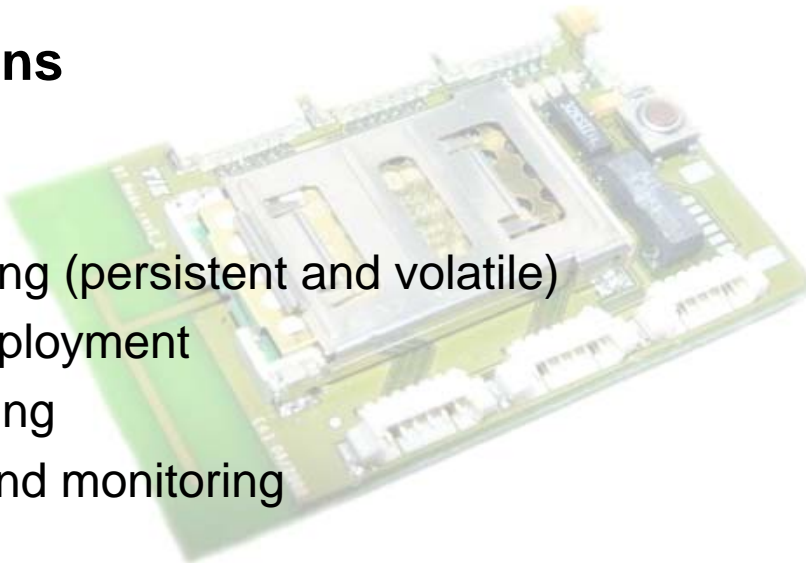

A backbone infrastructure like TreeNet only enables to deploy and test the ‘interesting’ distributed ad hoc networking algorithms...

What's next?

Implementation and evaluation of positioning services

BTnode rev3

- Bluetooth v1.2 with 4 simultaneous Piconets
- second low power radio frontend

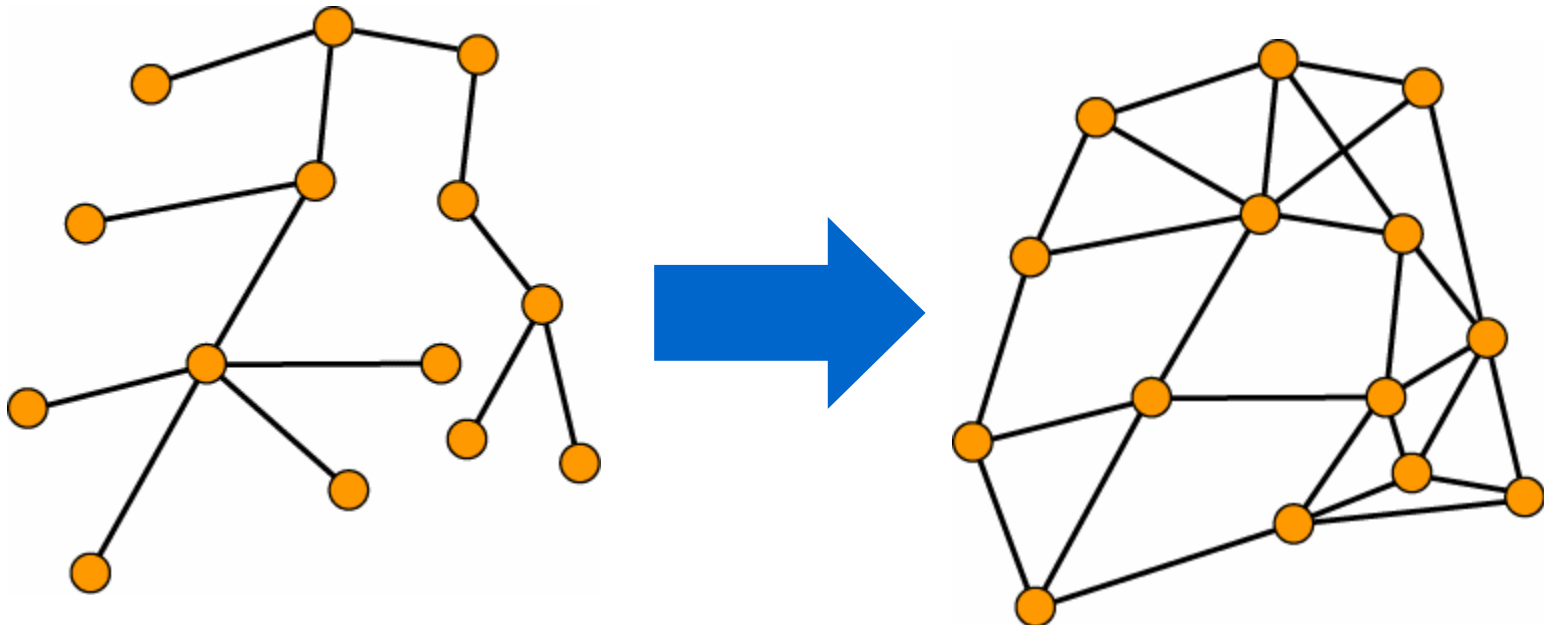

Acknowledgements

TreeNet collaborators

- Oliver Kasten, Friedemann Mattern, Matthias Ringwald, Kay Römer, Frank Siegemund
- Regina Bischoff, Roger Wattenhofer, Aaron Zollinger
- Jan Beutel, Martin Hinz, Lothar Thiele

Related publications:

J. Beutel: *Location Management in Wireless Sensor Networks*. Book Chapter in Handbook on Wireless Sensor Networks, CRC Press, 2004, to be published.

J. Beutel et al.: *Prototyping Wireless Sensor Networks with BTnodes*. 1st European Workshop on Wireless Sensor Networks (EWSN 2004).

R. Bischoff and R. Wattenhofer: *Analyzing Connectivity-Based Multi-Hop Ad Hoc Positioning*, PerCom 2004.

J. Beutel, O. Kasten and M. Ringwald: *BTnodes - A Distributed Platform for Sensor Nodes*. ACM SenSys 2003.

M. Leopold et al.: *Bluetooth and Sensor Networks – A Reality Check*. ACM SenSys 2003.

K. Römer: *The Lighthouse Location System for Smart Dust*. ACM MobiSys 2003.

O. Kasten, M. Langheinrich: *First Experiences with Bluetooth in the Smart-Its Distributed Sensor Network*. Workshop in Ubiquitous Computing and Communications (PACT 2001).